

Universal Fit Flat Free Hand Truck Tire Assembly Instructions

Replace Standard Hand Truck Tire:

STEP 1:

Remove cotter pin or axle cap. Slide old tire off of axle. Save washers to be used with new tire.

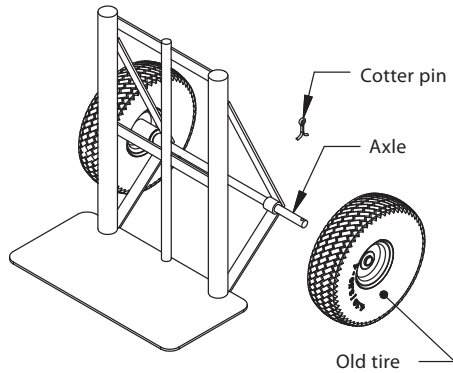

STEP 2:

Make sure that you place washers in the same place. Slide Marathon tire onto axle. Secure tire with cotter pin or axle cap.

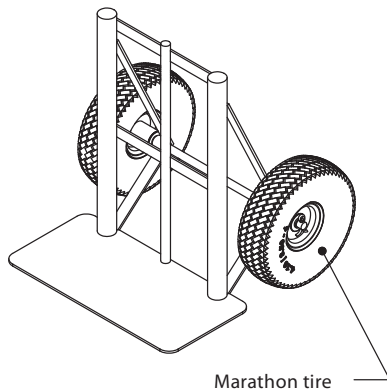

Replace Tire for Alternate Equipment:

(Non -Standard Hand Trucks, Casters, Compressor, Generators, etc.)

STEP 1:

Remove the old tire and measure the hub length to calculate the number of spacers that you need.

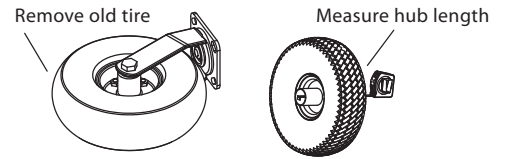

STEP 2:

If the axle is larger than 5/8", check the 3/4" or 1/2" replacement bushings on the axle. If the axle fits, remove the existing bearings with a screwdriver and a hammer by inserting the screwdriver through the top bearing hole to the backside of the bottom bearing. Pound out the bearing with the hammer. Flip tire and remove other bearing the same way. Place a piece of wood over the top of the 3/4" bushing and drive into the hub with the hammer. Repeat on the opposite side. If you find your axle does not fit in any of the supplied bearings, remove the bearing from your original tire and insert it into the new tire by following the steps above.

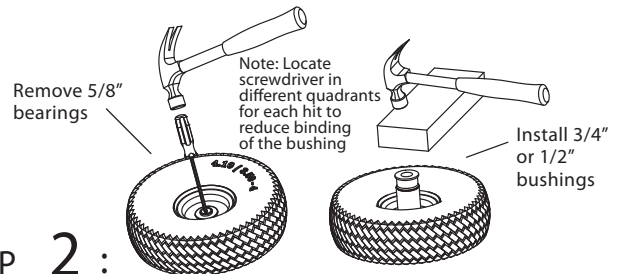

Bushings for Axle (Included in Box):

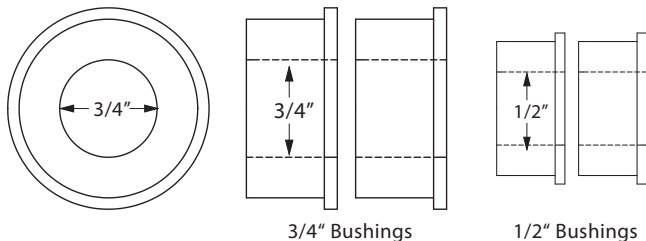

Spacers for Hub Length (Included in Box):

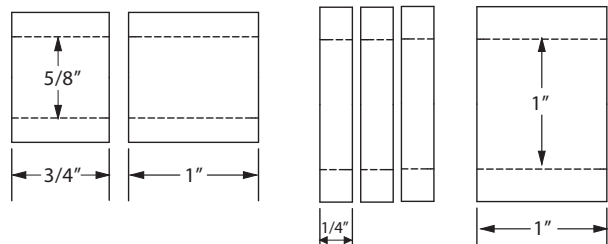

10" tire with 2.25" offset hub with 5/8" bearing. This replacement 4.10/3.50 - 4" tire is designed to fit most hand trucks. Using the adapter kit, this tire may also fit non-standard hand trucks, generators, pressure washers, in casters, and on a variety of other lawn and garden equipment.

Warning: When installing, wear safety glasses and gloves.